



● Compliance with International Codes  
● Compliance with State Codes

# ICC-ES Evaluation Report

## ESR-3173

Reissued December 2020

Revised June 2022

This report is subject to renewal December 2022.

**DIVISION: 03 00 00—CONCRETE**  
**Section: 03 16 00—Concrete Anchors**

**Division: 05 00 00—METALS**  
**Section: 05 05 19—Post-Installed Concrete Anchors**

**REPORT HOLDER:**

**MKT METALL-KUNSTSTOFF-TECHNIK GmbH & Co. KG**

**EVALUATION SUBJECT:**

**MKT SZ CARBON STEEL AND SZ A4 STAINLESS STEEL, HIGH LOAD ANCHORS FOR CRACKED AND UNCRACKED CONCRETE**

### 1.0 EVALUATION SCOPE

**Compliance with the following codes:**

- 2018, 2015, 2012 and 2009 *International Building Code*® (IBC)
- 2018, 2015, 2012 and 2009 *International Residential Code*® (IRC)
- 2013 *Abu Dhabi International Building Code* (ADIBC)†

†The ADIBC is based on the 2009 IBC. 2009 IBC code sections referenced in this report are the same sections in the ADIBC.

**Property evaluated:**

Structural

### 2.0 USES

The MKT SZ High Load Anchor is used to resist static, wind, and seismic (Seismic Design Categories A through F) tension and shear loads in cracked and uncracked normal-weight or lightweight concrete having a specified compressive strength,  $f'_c$ , of 2,500 psi to 8,500 psi (17.2 MPa to 58.6 MPa) [minimum of 24 MPa is required under ADIBC Appendix L, Section 5.1.1].

The anchoring system complies with Section 1901.3 of the 2018 and 2015 IBC, Section 1909 of the 2012 IBC and Section 1912 of the 2009 IBC, and is an alternative to cast-in-place anchors described in Section 1908 of the 2012 IBC and Section 1911 of the 2009 IBC. The anchors may also be used where an engineered design is submitted in accordance with Section R301.1.3 of the IRC.

### 3.0 DESCRIPTION

#### 3.1 MKT SZ:

**3.1.1 General:** The MKT SZ Carbon Steel or MKT SZ Stainless Steel A4 High Load Anchor, designated as the SZ or SZ A4 respectively, is a torque-set, sleeve-type mechanical expansion anchor. The SZ is comprised of seven components which vary slightly according to anchor diameter, as shown in Figure 1 of this report. It is available in three head configurations, illustrated in Figure 1 of this report. Only the sizes M8, M10 and M12 are available with a countersunk head.

All carbon steel parts receive a minimum 0.0002-inch-thick (5  $\mu$ m) galvanized zinc coating according to EN ISO 4042.

Dimensions and installation criteria are set forth in Table 1. The anchors are manufactured using metric units.

**3.1.2 SZ-B (Stud Style, Figure 1):** The anchor consists of a threaded stud (1), hexagon nut (7), steel washer (2), distance sleeve (3), collapsible ring (4), steel expansion sleeve (5) and threaded cone (6) (See Figure 1). This anchor is available in carbon steel or in stainless steel A4 (type 316). The material specifications are as follows:

- Threaded stud: Steel, strength class 8.8, EN ISO 898-1 or stainless steel, EN 10088
- Hexagon nut: Steel, strength class 8, EN ISO 898-2 or stainless steel, ISO 3506, strength class 70, coated
- Washer: Steel, EN 10139 or stainless steel, EN 10088
- Distance sleeve: Precision steel tubes EN10305-02 or EN 10305-3or stainless steel tubes, EN 10217-7 or EN 10216-5
- Ring: Polyethylene
- Expansion sleeve: Steel, EN 10139 or stainless steel, EN 10088
- Threaded cone: Steel, EN 10263 or EN 10087 or stainless steel, EN 10088, coated

Application of torque at the head of the anchor causes the cone to be drawn into the expansion sleeve. This in turn causes the sleeve to expand against the wall of the drilled hole. Application of the specified installation torque induces a tension force in the stud that is equilibrated by a precompression force in the concrete acting through the component being fastened. Deformation of the collapsible

ring prevents buildup of precompression in the distance sleeve in cases where the sleeve is in contact with the washer, and permits the closure of gaps between the concrete and the component being fastened. Application of tension loads that exceed the precompression force in the bolt will cause the cone to displace further into the expansion sleeve (follow-up expansion), generating additional expansion force.

**3.1.3 SZ-S (Bolt Style, Figure 1):** The anchor has the same components and material specifications as the SZ-B with the exception that the threaded stud and hexagonal nut are replaced by a hexagon head screw (8) made of carbon steel per EN ISO 898-1, strength class 8.8 or stainless steel, EN ISO 3506-1.

**3.1.4 SZ-SK (Countersunk Head, Figure 1):** The anchor has the same components and material specifications as the SZ-B with the exceptions that the threaded studs are replaced by a countersunk head screw (9) made of carbon steel per EN ISO 898-1, Strength class 8.8 or stainless steel, EN ISO 3506-1 and the washer is replaced by a countersunk washer (10) made of carbon steel per EN 10083-2 or stainless steel, EN 10088.

### 3.2 Concrete:

Normal-weight and lightweight concrete must comply with Sections 1903 and 1905 of the IBC.

## 4.0 DESIGN AND INSTALLATION:

### 4.1 Strength Design:

Design strength of anchors complying with the 2018 and 2015 IBC, as well as Section R301.1.3 of the 2015 IRC must be determined in accordance with ACI 318-14 Chapter 17 and this report.

Design strength of anchors complying with the 2012 IBC, as well as Section R301.1.3 of the 2012 IRC must be determined in accordance with ACI 318-11 Appendix D and this report.

Design strength of anchors complying with the 2009 IBC, as well as Section R301.1.3 of the 2009 IRC must be determined in accordance with ACI 318-08 Appendix D and this report.

Design parameters provided in Tables 2A, 2B, 3A and 3B are based on the 2018 and 2015 IBC (ACI 318-14) and the 2012 IBC (ACI 318-11) unless noted otherwise in Sections 4.1.1 through 4.1.11 and in Tables 2A, 2B, 3A and 3B of this report. The anchor design must satisfy the requirements in ACI 318-14 17.3.1 or ACI 318-11 D.4.1, as applicable, except as required in ACI 318-14 17.2.3 or ACI 318-11 D.3.3, as applicable. Strength reduction factors,  $\phi$ , as given in ACI 318-14 17.3.3 or ACI 318-11 D.4.3, as applicable, must be used for load combinations calculated in accordance with Section 1605.2 of the IBC and Section 5.3 of ACI 318-14 or Section 9.2 of ACI 318-11, as applicable. Strength reduction factors,  $\phi$ , as given in ACI 318-11 D.4.4 must be used for load combinations calculated in accordance with ACI 318-11 Appendix C. Strength reduction factors,  $\phi$ , corresponding to brittle steel elements must be used. An example calculation in accordance with the 2018, 2015 and 2012 IBC is provided in Figure 3 of this report.

**4.1.1 Requirements for Static Steel Strength in Tension,  $N_{sa}$ :** The nominal steel strength of a single anchor in tension,  $N_{sa}$ , in accordance with ACI 318-14 17.4.1.2 or ACI 318-11 D.5.1.2, as applicable, is provided in Tables 2A and 2B of this report. Strength reduction factors,  $\phi_{sa}$ , corresponding to brittle steel elements as described in Tables 2A and 2B must be used.

**4.1.2 Requirements for Static Concrete Breakout Strength in Tension,  $N_{cb}$  or  $N_{cbg}$ :** The nominal concrete

breakout strength of a single anchor or group of anchors in tension,  $N_{cb}$  and  $N_{cbg}$ , respectively, must be calculated according to ACI 318-14 17.4.2 or ACI 318-11 D.5.2, as applicable, with modifications as described in this section. The basic concrete breakout strength of a single anchor in tension,  $N_b$ , must be calculated according to ACI 318-14 17.4.2.2 or ACI 318-11 D.5.2.2, as applicable, using the values of  $h_{ef}$  and  $k_{cr}$  as given in Tables 2A and 2B. The value of  $f'_c$  used in the calculations must be limited to a maximum of 8,000 psi (55.2 MPa), in accordance with ACI 318-14 17.2.7 or ACI 318-11 D.3.7, as applicable. The nominal concrete breakout strength in tension in regions where analysis indicates no cracking at service loads in accordance with ACI 318-14 17.4.2.6 or ACI 318-11 D.5.2.6, as applicable, must be calculated with  $\psi_{c,N} = 1.0$  and using the value of  $k_{uncr}$  as given in Tables 2A and 2B.

**4.1.3 Requirements for Static Pullout Strength in Tension,  $N_{p,cr}$  and  $N_{p,uncr}$ :** The nominal pullout strength of a single anchor in accordance with ACI 318-14 17.4.3.1 and 17.4.3.2 or ACI 318-11 D.5.3.1 and D.5.3.2, as applicable, in cracked and uncracked concrete,  $N_{p,cr}$  and  $N_{p,uncr}$ , respectively, is given in Tables 2A and 2B. For all design cases  $\psi_{c,P} = 1.0$ . In accordance with ACI 318-14 17.4.3.2 or ACI 318-11 D.5.3.2, as applicable, the nominal pullout strength in cracked concrete may be calculated in accordance with the following equation:

$$N_{p,f'_c} = N_{p,cr} \sqrt{\frac{f'_c}{2,500}} \quad (\text{lb, psi}) \quad (\text{Eq-1})$$

$$N_{p,f'_c} = N_{p,cr} \sqrt{\frac{f'_c}{17.2}} \quad (\text{N, MPa})$$

In regions where analysis indicates no cracking in accordance with ACI 318-14 17.4.3.6 or ACI 318-11 D.5.3.6, as applicable, the nominal pullout strength in tension may be calculated in accordance with the following equation:

$$N_{p,f'_c} = N_{p,uncr} \sqrt{\frac{f'_c}{2,500}} \quad (\text{lb, psi}) \quad (\text{Eq-2})$$

$$N_{p,f'_c} = N_{p,uncr} \sqrt{\frac{f'_c}{17.2}} \quad (\text{N, MPa})$$

Where values for  $N_{p,cr}$  or  $N_{p,uncr}$  are not provided in Table 2A or Table 2B, the pullout strength in tension need not be evaluated.

**4.1.4 Requirements for Static Steel Strength in Shear,  $V_{sa}$ :** The nominal steel strength in shear,  $V_{sa}$ , of a single anchor in accordance with ACI 318-14 17.5.1.2 or ACI 318-11 D.6.1.2, as applicable, is given in Tables 3A and 3B of this report and must be used in lieu of values derived by calculation from ACI 318-14 Eq. 17.5.1.2b or ACI 318-11, Eq. D-29, as applicable. Strength reduction factors,  $\phi_{sa}$ , corresponding to brittle steel elements as described in Tables 3A and 3B must be used.

**4.1.5 Requirements for Static Concrete Breakout Strength of Anchors in Shear,  $V_{cb}$  or  $V_{cbg}$ :** The nominal concrete breakout strength for a single anchor or group of anchors in shear,  $V_{cb}$  and  $V_{cbg}$ , respectively, must be calculated in accordance with ACI 318-14 17.5.2 or ACI 318-11 D.6.2, as applicable, with modifications as described in this section. The basic concrete breakout strength in shear,  $V_b$ , must be calculated in accordance with ACI 318-14 17.5.2.2 or ACI 318-11 D.6.2.2, as applicable, using the values of  $l_e$  and  $d_a$  ( $d_o$ ) described in Tables 3A and 3B of this report. The value of  $l_e$  used in ACI 318-14 Eq. 17.5.2.2a or ACI 318-11 Eq. D-33, as applicable, must be taken as no greater than  $8d_a$ . The value of  $f'_c$  used for calculation purposes must not exceed 8,000 psi (55.2 MPa) in accordance with ACI 318-14 17.2.7 or ACI 318-11 D.3.7, as applicable.

**4.1.6 Requirements for Static Concrete Pryout Strength of Anchor in Shear,  $V_{cp}$  or  $V_{cpg}$ :** Static nominal concrete pryout shear strength for a single anchor or group of anchors,  $V_{cp}$  or  $V_{cpg}$ , respectively, must be calculated in accordance with ACI 318-14 17.5.3 or ACI 318-11 Section D.6.3, as applicable, modified by using the value of  $K_{cp}$  described in Tables 3A and 3B of this report and the value of  $N_{cb}$  or  $N_{cbg}$  as calculated in accordance with Section 4.1.2 of this report.

**4.1.7 Requirements for Minimum Member Thickness, Minimum Anchor Spacing, and Minimum Edge Distance:** In lieu of ACI 318-14 17.7.1 and 17.7.3 or ACI 318-11 D.8.1 and D.8.3, as applicable, values of  $s_{min}$  and  $c_{min}$  as given in Tables 1A and 1B of this report must be used. In lieu of ACI 318-14 17.7.5 or ACI 318-11 D.8.5, as applicable, minimum member thicknesses,  $h_{min}$ , as given in Tables 1A and 1B of this report must be used. Intermediate values between  $s_{min}$  and  $c_{min}$  can be calculated by linear interpolation. Figure A of this report provides more detail.

**4.1.8 Requirements for Critical Edge Distance,  $c_{ac}$ :** In applications where  $c < c_{ac}$  and supplemental reinforcement to control splitting of the concrete is not present, the concrete breakout strength in tension for uncracked concrete, calculated according to ACI 318-14 17.4.2 or ACI 318-11 D.5.2, as applicable, must be further multiplied by the factor  $\psi_{cp,N}$  given by Eq-3:

$$\psi_{cp,N} = \frac{c}{c_{ac}} \quad (\text{Eq-3})$$

whereby the factor  $\psi_{cp,N}$  need not be taken as less than  $\frac{1.5h_{ef}}{c_{ac}}$ . For all other cases,  $\psi_{cp,N} = 1.0$ .

In lieu of ACI 318-14 17.7.6 or ACI 318-11 D.8.6, as applicable, the critical edge distance,  $c_{ac}$ , required to develop the basic concrete breakout strength of a post-installed anchor in uncracked concrete without supplementary reinforcement, given in Tables 2A and 2B, must be used.

**4.1.9 Requirements for Seismic Design:** For load combinations including earthquake, the design must be performed according to ACI 318-14 17.2.3 or ACI 318-11 D.3.3, as applicable. Modifications to ACI 318-14 17.2.3 shall be applied under Section 1905.1.8 of the 2018 and 2015 IBC. For the 2012 IBC, Section 1905.1.9 shall be omitted. Modifications to ACI 318-08 D.3.3 shall be applied in accordance with Section 1908.1.9 of the 2009 IBC as applicable.

The nominal steel strength and the nominal concrete breakout strength for anchors in tension, and the nominal concrete breakout strength and pryout strengths for anchors in shear, must be calculated according to ACI 318-14 17.4 and 17.5 or ACI 318-11 D.5 and D.6, respectively, as applicable, taking into account the corresponding values given in Tables 2A and 2B or 3A and 3B of this report. The nominal steel strength for anchors in shear for seismic loads,  $V_{sa,eq}$ , must be evaluated with the values given in Tables 3A and 3B in lieu of  $V_{sa}$  as applicable. In accordance with ACI 318-14 17.4.3.2 or ACI 318-11 D.5.3.2, as applicable, the appropriate pullout strength in tension for seismic loads,  $N_{p,eq}$  given in Tables 2A and 2B must be used in lieu of  $N_p$ , as applicable. The value of  $N_{p,eq}$  may be adjusted by calculation for concrete strength in accordance with Eq-1 and Section 4.1.3. If no values for  $N_{p,eq}$  are given in Table 2A or Table 2B, the static design strength values govern and the pullout strength in tension does not need to be considered. The anchors comply with ACI 318-14 2.3 or ACI 318-11 D.1, as applicable, as brittle steel elements and must be designed in accordance with ACI 318-14 17.2.3.4, 17.2.3.5, 17.2.3.6, or 17.2.3.7; ACI 318-11 D.3.3.4, D.3.3.5, D.3.3.6 or D.3.3.7; or ACI 318-08

D.3.3.5 or D.3.3.6, as applicable. If no values for  $N_{p,eq}$  are given in Tables 2A and 2B, the static design strength values govern. (See Section 4.1.3 of this report.)

**4.1.10 Lightweight Concrete:** For the use of anchors in lightweight concrete, the modification factor  $\lambda_a$  equal to 0.8 $\lambda$  is applied to all values of  $\sqrt{f'_c}$  affecting  $N_n$  and  $V_n$ .

For ACI 318-14 (2018 and 2015 IBC), ACI 318-11 (2012 IBC) and ACI 318-08 (2009 IBC),  $\lambda$  shall be determined in accordance with the corresponding version of ACI 318.

**4.1.11 Interaction of Tensile and Shear Forces:** For loadings that include combined tension and shear, the design must be calculated in accordance with ACI 318-14 17.6 or ACI 318-11 D.7, as applicable.

## 4.2 Allowable Stress Design (ASD):

**4.2.1 General:** Design values for use with allowable stress design load combinations calculated in accordance with Section 1605.3 of the IBC must be established using the following relationships:

$$T_{allowable,ASD} = \frac{\phi N_n}{\alpha} \quad (\text{Eq-4})$$

and

$$V_{allowable,ASD} = \frac{\phi V_n}{\alpha} \quad (\text{Eq-5})$$

where

$T_{allowable,ASD}$  = Allowable tension load (lbf or kN).

$V_{allowable,ASD}$  = Allowable shear load (lbf or kN).

$\phi N_n$  = Lowest design strength of an anchor or anchor group in tension as determined in accordance with ACI 318-14 Chapter 17 and 2018 and 2015 IBC Section 1905.1.8, ACI 318-11 Appendix D, ACI 318-08 Appendix D and 2009 IBC Section 1908.1.9 and Section 4.1 of this report, as applicable (lbf or kN). For the 2012 IBC, Section 1905.1.9 shall be omitted.

$\phi V_n$  = Lowest design strength of an anchor or anchor group in shear as determined in accordance with ACI 318-14 Chapter 17 and 2018 and 2015 IBC Section 1905.1.8, ACI 318-11 Appendix D, ACI 318-08 Appendix D and 2009 IBC Section 1908.1.9 and Section 4.1 of this report, as applicable (lbf or kN). For the 2012 IBC, Section 1905.1.9 shall be omitted.

$\alpha$  = Conversion factor calculated as a weighted average of the load factors for the controlling load combination. In addition,  $\alpha$  must include all applicable factors to account for nonductile failure modes and required over-strength.

The requirements for member thickness, edge distance and spacing, as described in this report, must apply. Allowable stress design loads for selected cases are provided in Tables 4A and 4B.

**4.2.2 Interaction of Tensile and Shear Forces:** Interaction of tensile and shear loads must be calculated and consistent with ACI 318-14 17.6 or ACI 318-11 D.7, as applicable, as follows:

If  $T_{applied} \leq 0.2T_{allowable,ASD}$ , then the full allowable strength in shear,  $V_{allowable,ASD}$ , is permitted.

If  $T_{applied} \leq 0.2T_{allowable,ASD}$ , then the full allowable strength in tension,  $V_{allowable,ASD}$ , is permitted.

For all other cases:

$$\frac{T_{\text{applied}}}{T_{\text{allowable, ASD}}} + \frac{V_{\text{applied}}}{V_{\text{allowable, ASD}}} \leq 1.2 \quad (\text{Eq-6})$$

#### 4.3 Installation:

Installation parameters are provided in Tables 1A and 1B and in Figure 2 of this report. Anchors must be installed per the manufacturer's published instructions and this report. Anchor locations must comply with this report and plans and specifications approved by the code official. Anchors must be installed in holes drilled using carbide-tipped drill bits conforming to ANSI B212.15-1994 as given in Tables 1A and 1B. The nominal bit diameter must be equal to the nominal anchor size. The minimum drilled hole depth is given in Tables 1A and 1B. Prior to anchor installation, dust and debris must be removed from the hole using a hand pump, compressed air or a vacuum. The anchor must be driven into the predrilled hole using a hammer until the proper nominal embedment depth is achieved. The anchor is tightened until the installation torque,  $T_{\text{inst}}$ , specified in Table 1A or Table 1B is achieved.

#### 4.4 Special Inspection:

Special inspection is required in accordance with Section 1705.1.1 and Table 1705.3 of the 2018, 2015 and 2012 IBC or Section 1704.15 and Table 1704.4 of the 2009 IBC, as applicable. The special inspector must make periodic inspections during anchor installation to verify anchor type, anchor dimensions, concrete type, concrete compressive strength, hole dimensions, hole cleaning procedures, edge distance(s), anchor spacing(s), concrete thickness, embedment depth, tightening torque and adherence to the manufacturer's installation instructions.

The special inspector must be present as often as required in accordance with the "statement of special inspection." Under the IBC, additional requirements as set forth in Sections 1705, 1706 and 1707 must be observed, where applicable.

#### 5.0 CONDITIONS OF USE

The MKT SZ Carbon Steel or Stainless Steel High Load Anchors described in this report comply with, or are suitable alternatives to what is specified in, those codes listed in Section 1.0 of this report, subject to the following conditions:

- 5.1 Anchor sizes, dimensions, and installation parameters are as set forth in this report.
  - 5.2 The anchors must be installed in accordance with the manufacturer's published instructions and this report. In case of conflicts, this report governs.
  - 5.3 The anchors must be installed in cracked and uncracked, normal-weight or lightweight concrete having a specified compressive strength,  $f'_c$ , of 2,500 psi to 8,500 psi (17.2 MPa to 58.6 MPa) [minimum of 24 MPa is required under ADIBC Appendix L, Section 5.1.1].
  - 5.4 The values of  $f'_c$  used for calculation purposes must not exceed 8,000 psi (55.1 MPa).
  - 5.5 Strength design values must be established in accordance with Section 4.1 of this report.
  - 5.6 Allowable stress design values must be established in accordance with Section 4.2 of this report.
  - 5.7 Anchor spacing, edge distance, and minimum member thickness must comply with Tables 1A and 1B and Figure A.
  - 5.8 Prior to installation, calculations and details justifying that the applied loads comply with this report must be submitted to the code official for approval. The calculations and details must be prepared by a registered design professional where required by the statutes of the jurisdiction in which the project is to be constructed.
- 5.9 Since ICC-ES acceptance criteria for evaluating data to determine the performance of expansion anchors subjected to fatigue or shock loading is unavailable at this time, the use of these anchors under such conditions is beyond the scope of this report.
  - 5.10 Anchors may be installed in regions of concrete where cracking has occurred or where analysis indicates cracking may occur ( $f_t > f_r$ ), subject to the conditions of this report.
  - 5.11 Anchors may be used to resist short-term loading due to wind or seismic forces in locations designated as Seismic Design Categories A through F, subject to the conditions of this report.
  - 5.12 Where not otherwise prohibited in the code, MKT SZ and MKT SZ A4 anchors are permitted for use with fire-resistance-rated construction provided that at least one of the following conditions is fulfilled:
    - Anchors are used to resist wind or seismic forces only.
    - Anchors that support a fire-resistance-rated envelope or a fire-resistance-rated membrane are protected by approved fire-resistance-rated materials, or have been evaluated for resistance to fire exposure in accordance with recognized standards.
    - Anchors are used to support nonstructural elements.
  - 5.13 Use of zinc-coated carbon steel anchors is limited to dry, interior locations.
  - 5.14 Use of stainless steel anchors (type 316) is permitted for exterior exposure or damp environments.
  - 5.15 Special inspections are provided in accordance with Section 4.4 of this report.
  - 5.16 Anchors are manufactured in Weilerbach, Germany, under an approved quality-control program with inspections by ICC-ES.

#### 6.0 EVIDENCE SUBMITTED

Data in accordance with the ICC-ES Acceptance Criteria for Mechanical Anchors in Concrete Elements (AC193), approved October 2017 (Editorially revised April 2018), for use in cracked and uncracked concrete; and quality-control documentation.

#### 7.0 IDENTIFICATION

- 7.1 Anchors are identified by packaging labeled with the anchor name and size, the manufacturer's name (MKT) and contact information, and the evaluation report number (ESR-3173). The MKT SZ and MKT SZ A4 anchors have the letters SZ embossed on the expansion sleeve. The MKT SZ A4 has an additional marking of "A4" for stainless steel.
- 7.2 The report holder's contact information is the following:

**MKT METALL-KUNSTSTOFF-TECHNIK GmbH & Co. KG**  
**AUF DEM IMMEL 2**  
**WEILERBACH, 67685**  
**GERMANY**  
**+49 6374 9116-0**  
[www.mkt.de](http://www.mkt.de)  
[info@mkt.de](mailto:info@mkt.de)

TABLE 1A—SZ CARBON STEEL INSTALLATION INFORMATION<sup>1</sup>

SETTING INFORMATION	SYMBOL	UNITS	NOMINAL ANCHOR DIAMETER						
			M8	M10	M12	M16	M20	M24	
Anchor Outside Diameter	$d_a$	in. (mm)	0.45 (11.5)	0.57 (14.5)	0.69 (17.5)	0.93 (23.5)	1.08 (27.5)	1.26 (32)	
Drill Bit Diameter	$d_{bit}$	mm	12	15	18	24	28	32	
Minimum Hole Depth	$h_o$	in. (mm)	3.15 (80)	3.74 (95)	4.13 (105)	5.12 (130)	6.3 (160)	7.08 (180)	
Minimum Base Plate Clearance Hole Diameter <sup>2</sup>	$d_c$	in. (mm)	0.55 (14)	0.67 (17)	0.79 (20)	1.02 (26)	1.22 (31)	1.38 (35)	
Installation Torque (Carbon Steel)	$T_{inst}$	B / S SK	ft-lbf (N-m)	22.1 (30)	36.8 (50)	59 (80)	118 (160)	207 (280)	207 (280)
				18.4 (25)	40.6 (55)	51.6 (70)	-	-	-
Embedment Depth	$h_{nom}$	in. (mm)	2.72 (69)	3.25 (82.5)	3.72 (94.5)	4.65 (118)	5.83 (148)	6.65 (169)	
Effective Embedment Depth	$h_{ef}$	in. (mm)	2.4 (60)	2.8 (71)	3.1 (80)	3.94 (100)	4.92 (125)	5.92 (150)	
Minimum Edge Distance	$c_{min1}$	in. (mm)	2.4 (60)	2.8 (70)	3.5 (90)	4.7 (120)	7.1 (180)	5.92 (150)	
Minimum Spacing <sup>3</sup>	$s_{min1}$	in. (mm)	4.9 (125)	6.9 (175)	7.9 (200)	12.6 (320)	21.3 (540)	11.8 (300)	
Minimum Edge Distance	$c_{min2}$	in. (mm)	3.9 (100)	5.1 (130)	6.3 (160)	7.1 (180)	11.8 (300)	11.8 (300)	
Minimum Spacing <sup>4</sup>	$s_{min2}$	in. (mm)	2.4 (60)	3.1 (80)	3.1 (80)	3.9 (100)	4.9 (125)	5.92 (150)	
Minimum Concrete Thickness	$h_{min}$	in. (mm)	4.7 (120)	5.5 (140)	6.3 (160)	7.9 (200)	9.8 (250)	11.8 (300)	

For SI: 1 inch = 25.4 mm, 1 ft-lbf = 1.356 N-m.

<sup>1</sup>The information presented in this table must be used in conjunction with the design requirements of ACI 318-14 Chapter 17 or ACI 318-11 Appendix D, as applicable.

<sup>2</sup>The clearance must comply with applicable code requirements for the connected element.

<sup>3</sup> $s_{min1}$  applies when  $c_{min1}$  is provided.

<sup>4</sup> $s_{min2}$  applies when  $c_{min2}$  is provided.

TABLE 1B—SZ A4 STAINLESS STEEL INSTALLATION INFORMATION<sup>1</sup>

SETTING INFORMATION	SYMBOL	UNITS	NOMINAL ANCHOR DIAMETER				
			M8	M10	M12	M16	
Anchor Outside Diameter	$d_a$	in. (mm)	0.45 (11.5)	0.57 (14.5)	0.69 (17.5)	0.93 (23.5)	
Drill Bit Diameter	$d_{bit}$	Mm	12	15	18	24	
Minimum Hole Depth	$h_o$	in. (mm)	3.15 (80)	3.74 (95)	4.13 (105)	5.12 (130)	
Minimum Base Plate Clearance Hole Diameter <sup>2</sup>	$d_c$	in. (mm)	0.55 (14)	0.67 (17)	0.79 (20)	1.02 (26)	
Installation Torque (Stainless Steel)	$T_{inst}$	S	ft-lbf (N-m)	22.1 (30)	36.8 (50)	59 (80)	125 (170)
		B		25.8 (35)	40.5 (55)	66.3 (90)	125 (170)
		SK		12.9 (17.5)	31.3 (42.5)	36.8 (50)	-
Nominal Embedment Depth	$h_{nom}$	in. (mm)	2.72 (69)	3.25 (82.5)	3.72 (94.5)	4.67 (118.5)	
Effective Embedment Depth	$h_{ef}$	in. (mm)	2.4 (60)	2.8 (71)	3.1 (80)	3.9 (100)	
Minimum Edge Distance	$c_{min1}$	in. (mm)	2.9 (75)	3.3 (85)	3.9 (100)	7.1 (180)	
Minimum Spacing <sup>3</sup>	$s_{min1}$	in. (mm)	5.3 (135)	7.2 (185)	8.3 (210)	7.1 (180)	
Minimum Edge Distance	$c_{min2}$	in. (mm)	3.9 (100)	5.5 (140)	6.7 (170)	7.1 (180)	
Minimum Spacing <sup>4</sup>	$s_{min2}$	in. (mm)	2.8 (70)	3.3 (85)	3.9 (100)	7.1 (180)	
Minimum Concrete Thickness	$h_{min}$	in. (mm)	4.7 (120)	5.5 (140)	6.3 (160)	7.8 (200)	
Thickness of fixture	$t_{fix,min}$	in. (mm)	0	0	0	0	
SZ-B and SZ-S	$t_{fix,max}$	in. (mm)	7.8 (200)	7.8 (200)	9.8 (250)	11.8 (300)	
Thickness of fixture	$t_{fix,min}$ <sup>5</sup>	in. (mm)	0.4 (10)	0.5 (14)	0.7 (18)	-	
SZ-SK	$t_{fix,max}$	in. (mm)	7.8 (200)	7.8 (200)	9.8 (250)	-	
Thickness of countersunk washer SZ-SK	$t_{sk}$	in. (mm)	0.20 (5)	0.24 (6)	0.27 (7)	-	

For SI: 1 inch = 25.4 mm, 1 ft-lbf = 1.356 N-m.

<sup>1</sup>The information presented in this table must be used in conjunction with the design requirements of ACI 318-14 Chapter 17 or ACI 318-11 Appendix D, as applicable.

<sup>2</sup>The clearance must comply with applicable code requirements for the connected element.

<sup>3</sup> $s_{min1}$  applies when  $c_{min1}$  is provided.

<sup>4</sup> $s_{min2}$  applies when  $c_{min2}$  is provided.

<sup>5</sup>Depending on the present shear load, the thickness of the fixture may be reduced to the thickness of the countersunk washer  $t_{sk}$ . It must be verified that the present shear load can be transferred completely into the distance sleeve (bearing of hole).

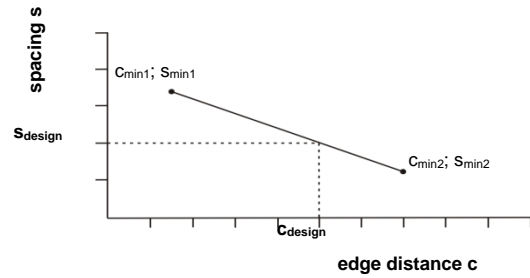
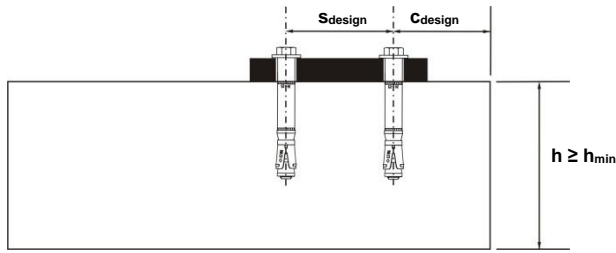
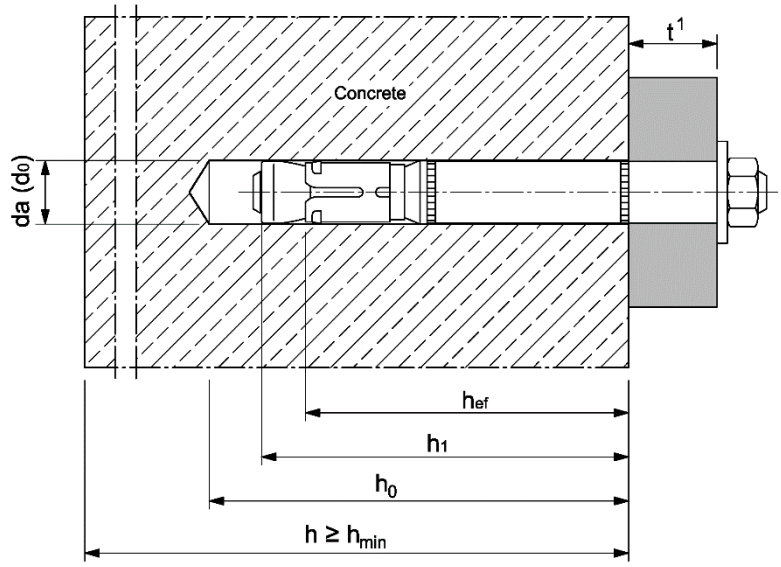
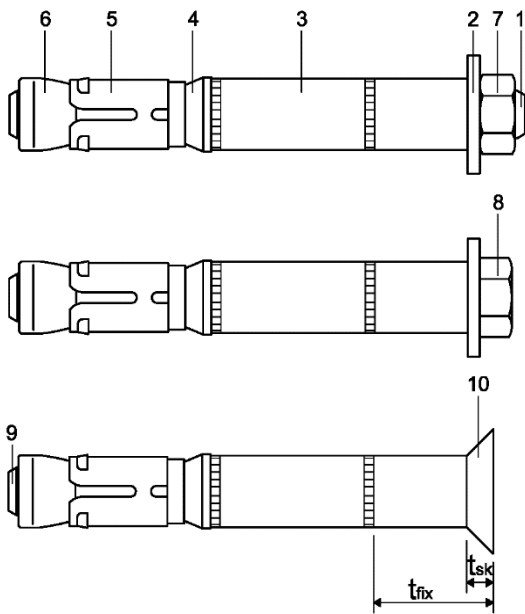

FIGURE A—EXAMPLE OF ALLOWABLE INTERPOLATION OF MINIMUM EDGE DISTANCE AND MINIMUM SPACING



<sup>1</sup> Thickness of fixture

FIGURE 1—MKT SZ ANCHOR (STUD, BOLT, COUNTERSUNK)

FIGURE 2—MKT SZ ANCHOR (INSTALLED)

TABLE 2A—SZ CARBON STEEL CHARACTERISTIC TENSION STRENGTH DESIGN INFORMATION<sup>1</sup>

CHARACTERISTIC	SYMBOL	UNITS	NOMINAL ANCHOR DIAMETER					
			M8	M10	M12	M16	M20	M24
Anchor Category	1,2 or 3	-	3	1	1	1	1	1
Embedment Depth	$h_{nom}$	in. (mm)	2.76 (70)	3.31 (84)	3.74 (95)	4.65 (118)	5.83 (148)	6.65 (169)
<b>Steel Strength in Tension</b>								
Specified Yield Strength	$f_{ya}$	psi (N/mm <sup>2</sup> )	92,888 (640)	92,888 (640)	92,888 (640)	92,888 (640)	92,888 (640)	92,888 (640)
Specified Tensile Strength	$f_{uta}$	psi (N/mm <sup>2</sup> )	116,110 (800)	116,110 (800)	116,110 (800)	116,110 (800)	116,110 (800)	116,110 (800)
Effective Tensile Stress Area	$A_{se}$	in <sup>2</sup> (mm <sup>2</sup> )	0.06 (36.6)	0.09 (58)	0.13 (84.3)	0.24 (156.7)	0.38 (244.8)	0.55 (352.8)
Tension Resistance of Steel	$N_{sa}$	lbf (kN)	6,580 (29.3)	10,427 (46.4)	15,155 (67.4)	28,171 (125.4)	44,009 (195.8)	63,486 (282.4)
Strength Reduction Factor-Steel Failure <sup>2</sup>	$\Phi_{sa}$	-	0.65	0.65	0.65	0.65	0.65	0.65
<b>Concrete Breakout Strength in Tension</b>								
Effective Embedment Depth	$h_{ef}$	in. (mm)	2.4 (60)	2.8 (71)	3.1 (80)	3.94 (100)	4.92 (125)	5.92 (150)
Critical Edge Distance	$c_{ac}$	in. (mm)	5.2 (132)	7.0 (178)	6.3 (160)	9.1 (230)	11.3 (288)	12.2 (310)
Effectiveness Factor-Uncracked Concrete	$k_{unscr}$	-	24 (10)	24 (10)	24 (10)	27 (11.3)	27 (11.3)	27 (11.3)
Effectiveness Factor-Cracked Concrete	$k_{scr}$	-	17 (7.1)	17 (7.1)	17 (7.1)	21 (8.8)	21 (8.8)	24 (10)
Modification Factor	$\Psi_{c,N}$	-	1.0	1.0	1.0	1.0	1.0	1.0
Strength Reduction Factor-Concrete Breakout Failure <sup>3</sup>	$\Phi_{cb}$	-	0.45	0.65	0.65	0.65	0.65	0.65
<b>Pull-Out Strength in Tension</b>								
Pull-Out Resistance Cracked Concrete ( $f'_c = 2,500$ psi) <sup>5</sup>	$N_{pn,cr}$	lbf (kN)	2,911 (12.9)	N/A <sup>4</sup>	N/A <sup>4</sup>	N/A <sup>4</sup>	N/A <sup>4</sup>	N/A <sup>4</sup>
Pull-Out Resistance Uncracked Concrete ( $f'_c = 2,500$ psi) <sup>5</sup>	$N_{pn,unscr}$	lbf (kN)	3,887 (17.3)	4,734 (21.1)	N/A <sup>4</sup>	N/A <sup>4</sup>	N/A <sup>4</sup>	N/A <sup>4</sup>
Strength Reduction Factor-Pullout Failure <sup>6</sup>	$\Phi_p$	-	0.45	0.65	0.65	0.65	0.65	0.65
<b>Tension Strength for Seismic Applications</b>								
Tension Resistance of Single Anchor for Seismic Loads ( $f'_c = 2,500$ psi) <sup>5</sup>	$N_{pn,eq}$	lbf (kN)	2,911 (12.9)	N/A <sup>4</sup>	N/A <sup>4</sup>	N/A <sup>4</sup>	N/A <sup>4</sup>	16,748 (74.5)
Strength Reduction Factor-Pullout Failure <sup>6</sup>	$\Phi_{eq}$	-	0.45	0.65	0.65	0.65	0.65	0.65
Axial Stiffness in Service Load Range, Cracked Concrete <sup>7</sup>	$\beta_{cr}$	lb/in. (kN/mm)	145,923 (25.6)	229,946 (40.3)	143,155 (25.1)	57,102 (10)	142,754 (25)	217,714 (38.1)
Axial Stiffness in Service Load Range, Uncracked Concrete <sup>7</sup>	$\beta_{unscr}$	lb/in. (kN/mm)	386,670 (67.7)	455,987 (80.0)	483,412 (84.7)	114,203 (20)	485,364 (85)	1,056,000 (184.8)

For SI: 1 inch = 25.4mm, 1lbf = 0.00445kN, 1 lb/in = 0.175 N/mm, 1 psi = 0.00689 N/mm<sup>2</sup>, 1 in<sup>2</sup> = 645 mm<sup>2</sup>.

<sup>1</sup>The information presented in this table must be used in conjunction with the design requirements of ACI 318-14 Chapter 17 or ACI 318-11 Appendix D, as applicable.

<sup>2</sup>The tabulated value of  $\Phi_{sa}$  applies when the load combinations of Section 1605.2 of the IBC, ACI 318-14 Section 5.3, or ACI 318-11 Section 9.2, as applicable, are used. If the load combinations of ACI 318-11 Appendix C are used, the appropriate value of  $\Phi_{sa}$  must be determined in accordance with ACI 318-11 D.4.4. The anchors are brittle steel elements as defined in ACI 318-14 2.3 or ACI 318-11 D.1, as applicable.

<sup>3</sup>The tabulated value of  $\Phi_{cb}$  applies when both the load combinations of Section 1605.2 of the IBC, ACI 318-14 Section 5.3 or ACI 318-11 Section 9.2, as applicable, are used and the requirements of ACI 318-14 17.3.3(c) or ACI 318-11 D.4.3(c), as applicable, for Condition B are satisfied. For installations where complying supplementary reinforcement can be verified, the  $\Phi_{cb}$  factors described in ACI 318-14 17.3.3(c) or ACI 318-11 D.4.3(c), as applicable, for Condition A are allowed. If the load combinations of ACI 318 Appendix C are used, the appropriate value of  $\Phi_{cb}$  must be determined in accordance with ACI 318-11 D.4.4.

<sup>4</sup>As described in Section 4.1.3 of this report, N/A (Not Applicable) denotes that pullout resistance is not critical and need not be considered.

<sup>5</sup>For all design cases,  $\Psi_{c,N} = 1.0$ . The appropriate effectiveness factor for cracked concrete ( $k_{scr}$ ) or uncracked concrete ( $k_{unscr}$ ) must be used.

<sup>6</sup>The tabulated value of  $\Phi_p$  or  $\Phi_{eq}$  applies when both the load combinations of Section 1605.2 of the IBC, ACI 318-14 Section 5.3 or ACI 318-11 Section 9.2, as applicable, are used and the requirements of ACI 318-14 17.3.3(c) or ACI 318-11 D.4.3(c), as applicable, for Condition B are satisfied. Condition B applies where supplementary reinforcement is not provided or where pullout strength governs. For installations where complying supplementary reinforcement can be verified, the  $\Phi$  factors described in ACI 318-14 17.3.3(c) or ACI 318-11 D.4.3(c), as applicable, for Condition A are allowed. If the load combinations of ACI 318 Appendix C are used, appropriate value of  $\Phi$  must be determined in accordance with ACI 318-11 D.4.4.

<sup>7</sup>Minimum axial stiffness values. Actual stiffness may vary depending on the concrete strength, loading and geometry of the application.

TABLE 2B—SZ A4 STAINLESS STEEL CHARACTERISTIC TENSION STRENGTH DESIGN INFORMATION<sup>1</sup>

CHARACTERISTIC	SYMBOL	UNITS	NOMINAL ANCHOR DIAMETER				
			M8	M10	M12	M16	
Anchor Category	1, 2 or 3	-	1	1	1	1	
Embedment Depth	$h_{nom}$	in. (mm)	2.72 (69)	3.25 (82.5)	3.72 (94.5)	4.67 (118.5)	
<b>Steel Strength in Tension</b>							
Specified Yield Strength	$f_{ya}$	S	psi (N/mm <sup>2</sup> )	65,312 (450)	65,312 (450)	65,312 (450)	65,312 (450)
		B		81,277 (560)	81,277 (560)	81,277 (560)	81,277 (560)
		SK		65,312 (450)	65,312 (450)	65,312 (450)	65,312 (450)
Specified Tensile Strength	$f_{uta}$	psi (N/mm <sup>2</sup> )	101,600 (700)	101,600 (700)	101,600 (700)	101,600 (700)	
Effective Tensile Stress Area	$A_{se}$	in <sup>2</sup> (mm <sup>2</sup> )	0.06 (36.6)	0.09 (58)	0.13 (84.3)	0.24 (157)	
Tension Resistance of Steel	$N_{sa}$	lbf (kN)	5,845 (26)	9,217 (41)	13,263 (59)	24,429 (110)	
Strength Reduction Factor-Steel Failure <sup>2</sup>	$\Phi_{sa}$	-	0.65	0.65	0.65	0.65	
<b>Concrete Breakout Strength in Tension</b>							
Effective Embedment Depth	$h_{ef}$	in. (mm)	2.4 (60)	2.8 (71)	3.1 (80)	3.94 (100)	
Critical Edge Distance	$c_{ac}$	in. (mm)	7.1 (180)	9.3 (235)	10.4 (265)	13.0 (330)	
Effectiveness Factor-Uncracked Concrete	$k_{uncr}$	-	24 (10.0)	24 (10.0)	24 (10.0)	27 (11.3)	
Effectiveness Factor-Cracked Concrete	$k_{cr}$	-	17 (7.1)	17 (7.1)	17 (7.1)	24 (10)	
Modification factor for uncracked concrete <sup>8</sup>	$\Psi_{c,N}$	-	1.0	1.0	1.0	1.0	
Strength Reduction Factor-Concrete Breakout Failure <sup>3</sup>	$\Phi_{cb}$	-	0.65	0.65	0.65	0.65	
<b>Pull-Out Strength in Tension</b>							
Pull-Out Resistance Cracked Concrete ( $f'_c = 2,500$ psi) <sup>5</sup>	$N_{pn,cr}$	lbf (kN)	2,700 (12)	3,600 (16)	N/A <sup>4</sup>	N/A <sup>4</sup>	
Pull-Out Resistance Uncracked Concrete ( $f'_c = 2,500$ psi) <sup>5</sup>	$N_{pn,uncr}$	lbf (kN)	3,600 (16)	5,600 (25)	N/A <sup>4</sup>	N/A <sup>4</sup>	
Strength Reduction Factor-Pullout Failure <sup>6</sup>	$\Phi_p$	-	0.65	0.65	0.65	0.65	
<b>Tension Strength for Seismic Applications</b>							
Tension Resistance of Single Anchor for Seismic Loads ( $f'_c = 2,500$ psi) <sup>5</sup>	$N_{pn,eq}$	lbf (kN)	2,700 (12)	3,600 (16)	5,685 (25.3)	N/A <sup>4</sup>	
Strength Reduction Factor-Pullout Failure <sup>6</sup>	$\Phi_{eq}$	-	0.65	0.65	0.65	0.65	
Axial Stiffness in Service Load Range, Cracked Concrete <sup>7</sup>	$\beta_{cr}$	lb/in. (kN/mm)	74,200 (13)	62,800 (11)	85,600 (15)	103,000 (18)	
Axial Stiffness in Service Load Range, Uncracked Concrete <sup>7</sup>	$\beta_{uncr}$	lb/in. (kN/mm)	285,000 (50)	211,000 (37)	114,000 (20)	365,000 (64)	

For SI: 1 inch = 25.4mm, 1lbf = 4.45N, 1 lb/in = 0.175 N/mm, 1 psi = 6.89 Pa, 1 in<sup>2</sup> = 645 mm<sup>2</sup>, 1 lb/in = 0.175 N/mm.

<sup>1</sup>The information presented in this table must be used in conjunction with the design requirements of ACI 318-14 Chapter 17 or ACI 318-11 Appendix D, as applicable.

<sup>2</sup>The tabulated value of  $\Phi_{sa}$  applies when the load combinations of Section 1605.2 of the IBC, ACI 318-14 Section 5.3 or ACI 318-11 Section 9.2, as applicable, are used. If the load combinations of ACI 318-11 Appendix C are used, the appropriate value of  $\Phi_{sa}$  must be determined in accordance with ACI 318-11 D.4.4. The anchors are brittle steel elements as defined in ACI 318-14 2.3 or ACI 318-11 D.1, as applicable.

<sup>3</sup>The tabulated value of  $\Phi_{cb}$  applies when both the load combinations of Section 1605.2 of the IBC, ACI 318-14 Section 5.3 or ACI 318-11 Section 9.2, as applicable, are used and the requirements of ACI 318-14 17.3.3(c) or ACI 318-11 D.4.3(c), as applicable, for Condition B are satisfied. For installations where complying supplementary reinforcement can be verified, the  $\Phi_{cb}$  factors described in ACI 318-14 17.3.3(c) or ACI 318-11 D.4.3(c), as applicable, for Condition A are allowed. If the load combinations of ACI 318-11 Appendix C are used, the appropriate value of  $\Phi_{cb}$  must be determined in accordance with ACI 318-11 D.4.4.

<sup>4</sup>As described in Section 4.1.3 of this report, N/A (Not Applicable) denotes that pullout resistance is not critical and does not need to be considered.

<sup>5</sup>The characteristic pull-out resistance for greater concrete compressive strengths may be increased by multiplying the tabular value by  $(f'_c / 2,500)^{0.5}$  in accordance with Section 4.1.3 of this report.

<sup>6</sup>The tabulated value of  $\Phi_p$  or  $\Phi_{eq}$  applies when both the load combinations of Section 1605.2 of the IBC, ACI 318-14 Section 5.3 or ACI 318-11 Section 9.2, as applicable, are used and the requirements of ACI 318-14 17.3.3(c) or ACI 318-11 D.4.3(c), as applicable, for Condition B are satisfied. Condition B applies where supplementary reinforcement is not provided or where pullout strength governs. For installations where complying supplementary reinforcement can be verified, the  $\Phi$  factors described in ACI 318-14 17.3.3(c) or ACI 318-11 D.4.3(c), as applicable for Condition A are allowed. If the load combinations of ACI 318-11 Appendix C are used, appropriate value of  $\Phi$  must be determined in accordance with ACI 318-11 D.4.4.

<sup>7</sup>Minimum axial stiffness value. Actual stiffness may vary depending on the concrete strength, loading and geometry of the application.

<sup>8</sup>For all design cases,  $\Psi_{c,N} = 1.0$ . The appropriate effectiveness factor for cracked concrete ( $k_{cr}$ ) or uncracked concrete ( $k_{uncr}$ ) must be used.



TABLE 3A—SZ CARBON STEEL CHARACTERISTIC SHEAR STRENGTH DESIGN INFORMATION<sup>1</sup>

CHARACTERISTIC	SYMBOL	UNITS	NOMINAL ANCHOR DIAMETER														
			M8			M10			M12			M16		M20		M24	
Anchor type			B	S	SK	B	S	SK	B	S	SK	B	S	B	S	B	S
Anchor Category	1,2 or 3	-	3			1			1			1		1		1	
Embedment Depth	$h_{nom}$	in. (mm)	2.76 (70)			3.31 (84)			3.74 (95)			4.65 (118)		5.83 (148)		6.65 (169)	
<b>Steel Strength in Shear</b>																	
Shear Resistance of Steel	$V_{sa}$	lb (kN)	5,457 (24.3)			8,793 (39.1)			13,037 (58.0)			19,100 (85)	21,600 (96)	22,400 (100)	27,600 (123)	44,984 (200.1)	
Strength Reduction Factor-Steel Failure <sup>2</sup>	$\Phi_{sa}$	-	0.6			0.6			0.6			0.6		0.6		0.6	
<b>Concrete Breakout Strength in Shear</b>																	
Anchor Outside Diameter	$d_a (d_{nom})$	in. (mm)	0.45 (11.5)			0.57 (14.5)			0.69 (17.5)			0.93 (23.5)		1.08 (27.5)		1.26 (32)	
Load Bearing Length of Anchor in Shear	$l_e$	in. (mm)	0.91 (23)			1.14 (29)			1.38 (35)			1.85 (47)		2.17 (55)		2.52 (64)	
Strength Reduction Factor-Concrete Breakout Failure <sup>3</sup>	$\Phi_{cb}$	-	0.7			0.7			0.7			0.7		0.7		0.7	
<b>Concrete Pryout Strength in Shear</b>																	
Coefficient for Pryout Strength	$k_{cp}$	-	1			2			2			2		2		2	
Strength Reduction Factor-Concrete Pryout Failure <sup>4</sup>	$\Phi_{cp}$	-	0.7			0.7			0.7			0.7		0.7		0.7	
<b>Shear Strength for Seismic Applications</b>																	
Shear Resistance of Single Anchor for Seismic Loads ( $f'_c = 2,500$ psi)	$V_{sa,eq}$	lb (kN)	3,934 (17.5)			6,627 (29.5)			8,977 (39.9)			9,217 (41)		22,256 (99)		35,992 (160.1)	
Strength Reduction Factor-Steel Failure	$\Phi_{eq}$	-	0.6			0.6			0.6			0.6		0.6		0.6	

TABLE 3B—SZ A4 STAINLESS STEEL CHARACTERISTIC SHEAR STRENGTH DESIGN INFORMATION<sup>1</sup>

CHARACTERISTIC	SYMBOL	UNITS	NOMINAL ANCHOR DIAMETER							
			M8	M10	M12	M16				
Anchor Category	1,2 or 3	-	1							
Embedment Depth	$h_{nom}$	in. (mm)	2.72 (69)		3.25 (82.5)		3.72 (94.5)		4.67 (118.5)	
<b>Steel Strength in Shear</b>										
Shear Resistance of Steel	$V_{sa}$	lb (kN)	5,463 (24.3)		8,273 (36.8)		13,668 (60.8)		19,963 (88.8)	
Strength Reduction Factor-Steel Failure <sup>2</sup>	$\Phi_{sa}$	-	0.60		0.60		0.60		0.60	
<b>Concrete Breakout Strength in Shear</b>										
Anchor Outside Diameter	$d_a (d_{nom})$	in. (mm)	0.45 (11.5)		0.57 (14.5)		0.69 (17.5)		0.93 (23.5)	
Load Bearing Length of Anchor in Shear	$l_e$	in. (mm)	0.91 (23)		1.14 (29)		1.38 (35)		1.85 (47)	
Strength Reduction Factor-Concrete Breakout Failure <sup>3</sup>	$\Phi_{cb}$	-	0.7		0.7		0.7		0.7	
<b>Concrete Pryout Strength in Shear</b>										
Coefficient for Pryout Strength	$k_{cp}$	-	2		2		2		2	
Strength Reduction Factor-Concrete Pryout Failure <sup>4</sup>	$\Phi_{cp}$	-	0.7		0.7		0.7		0.7	
<b>Shear Strength for Seismic Applications</b>										
Shear Resistance of Single Anchor for Seismic Loads ( $f'_c = 2,500$ psi)	$V_{sa,eq}$	lb (kN)	2,158 (9.6)		3,012 (13.4)		5,485 (24.4)		15,983 (71.1)	
Strength Reduction Factor-Steel Failure	$\Phi_{eq}$	-	0.60		0.60		0.60		0.60	

For SI: 1 inch = 25.4mm, 1 lbf = 0.00445 kN, 1 psi = 0.00689 N/mm<sup>2</sup>, 1 in<sup>2</sup> = 645 mm<sup>2</sup>.

<sup>1</sup>The information presented in this table must be used in conjunction with the design requirements of ACI 318-14 Chapter 17 or ACI 318-11 Appendix D, as applicable.  
<sup>2</sup>The tabulated value of  $\Phi_{sa}$  applies when the load combinations of Section 1605.2 of the IBC, ACI 318-14 Section 5.3, or ACI 318-11 Section 9.2, as applicable, are used. If the load combinations of ACI 318-11 Appendix C are used, the appropriate value of  $\Phi_{sa}$  must be determined in accordance with ACI 318-11 D.4.4.  
<sup>3</sup>The tabulated value of  $\Phi_{cb}$  applies when both the load combinations of Section 1605.2 of the IBC, ACI 318-14 Section 5.3 or ACI 318-11 Section 9.2, as applicable, are used and the requirements of ACI 318-14 17.3.3(c) or ACI 318-11 D.4.3(c), as applicable, for Condition B are satisfied. For installations where complying supplementary reinforcement can be verified, the  $\Phi_{cb}$  factors described in ACI 318-14 17.3.3(c) or ACI 318-11 D.4.3(c), as applicable, for Condition A are allowed. If the load combinations of ACI 318-11 Appendix C are used, the appropriate value of  $\Phi_{cb}$  must be determined in accordance with ACI 318-11 D.4.4.  
<sup>4</sup>The tabulated value of  $\Phi_{cp}$  applies when both the load combinations of Section 1605.2 of the IBC, ACI 318-14 Section 5.3 or ACI 318-11 Section 9.2, as applicable, are used and the requirements of ACI 318-14 17.3.3(c) or ACI 318-11 D.4.3(c), as applicable, for Condition B are satisfied. Condition B applies where supplementary reinforcement is not provided or where pryout strength governs. For installations where complying supplementary reinforcement can be verified, the  $\Phi$  factors described in ACI 318-14 17.3.3(c) or ACI 318-11 D.4.3(c), as applicable, for Condition A are allowed. If the load combinations of ACI 318-11 Appendix C are used, the appropriate value of  $\Phi$  must be determined in accordance with ACI 318-11 D.4.4.

**TABLE 4A—SZ CARBON STEEL EXAMPLE ALLOWABLE STRESS DESIGN VALUES FOR ILLUSTRATIVE PURPOSES<sup>1,2,3,4,5,6,7</sup>**

Nominal Anchor Diameter	Embedment Depth, $h_{nom}$ (in.)	Effective Embedment Depth, $h_{ef}$ (in.)	Allowable Tension Load, $\Phi N_n / \alpha$ (lbf)
M8	2.76	2.4	1,182
M10	3.31	2.8	2,079
M12	3.74	3.1	2,877
M16	4.65	3.94	4,637
M20	5.83	4.92	6,470
M24	6.65	5.92	8,540

For SI: 1 inch = 25.4 mm, ft-lbf = 1.356 N-m, 1 lbf = 4.45 N.

<sup>1</sup>Single anchor with static tension load only

<sup>2</sup>Concrete determined to remain uncracked for the life of the anchorage

<sup>3</sup>Load combination from ACI 318-14 Section 5.3 or ACI 318-11 Section 9.2, as applicable, (no seismic loading) with  $\Phi_{sa} = 0.65$ ,  $\Phi_{cb} = 0.45$ , and  $\Phi_p = 0.45$  (M8) and  $\Phi_{sa} = 0.65$ ,  $\Phi_{cb} = 0.65$ , and  $\Phi_p = 0.65$  (M10 – M24)

<sup>4</sup>30% dead load and 70% live load. Controlling load combination is  $1.2D + 1.6L$ . Calculation of  $\alpha$  based on weighted average:  
 $\alpha = 0.3 \cdot 1.2 + 0.7 \cdot 1.6 = 1.48$

<sup>5</sup> $f'_c = 2,500$  psi (normal weight concrete)

<sup>6</sup> $C_{a1} = C_{a2} \geq C_{ac}$

<sup>7</sup> $h \geq h_{min}$

**TABLE 4B—SZ A4 STAINLESS STEEL EXAMPLE ALLOWABLE STRESS DESIGN VALUES FOR ILLUSTRATIVE PURPOSES<sup>1,2,3,4,5,6,7</sup>**

Nominal Anchor Diameter	Nominal Embedment Depth, $h_{nom}$ (in.)	Effective Embedment Depth, $h_{ef}$ (in.)	Allowable Tension Load, $\Phi N_n / \alpha$ (lbf)
M8	2.72	2.4	1,581
M10	3.25	2.8	2,459
M12	3.72	3.1	2,877
M16	4.67	3.94	4,637

For SI: 1 inch = 25.4 mm, ft-lbf = 1.356 N-m, 1 lbf = 4.45 N.

<sup>1</sup>Single anchor with static tension load only

<sup>2</sup>Concrete determined to remain uncracked for the life of the anchorage

<sup>3</sup>Load combination from ACI 318-14 Section 5.3 or ACI 318-11 Section 9.2, as applicable, (no seismic loading) with  $\Phi_{sa} = 0.65$ ,  $\Phi_{cb} = 0.65$ , and  $\Phi_p = 0.65$ .

<sup>4</sup>30% dead load and 70 % live load. Controlling load combination is  $1.2D + 1.6L$ . Calculation of  $\alpha$  based on weighted average:  
 $\alpha = 0.3 \cdot 1.2 + 0.7 \cdot 1.6 = 1.48$

<sup>5</sup> $f'_c = 2,500$  psi (normal weight concrete)

<sup>6</sup> $C_{a1} = C_{a2} \geq C_{ac}$

<sup>7</sup> $h \geq h_{min}$

**INSTALLATION INSTRUCTIONS**

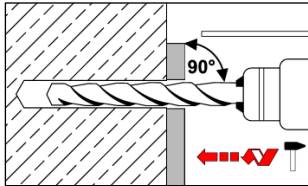

**Step 1:**  
Select the correct diameter metric drill bit, drill hole to minimum required hole depth or deeper.

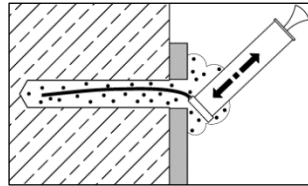

**Step 2:**  
Remove drilling debris with a blowout bulb, compressed air or vacuum.

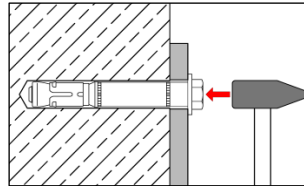

**Step 3:**  
Using a hammer, tap the anchor through the part being fastened into the drilled hole until the washer is in contact with the fastened part. Do not expand anchor by hand prior to installation.

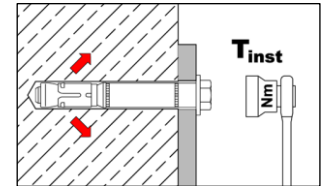

**Step 4:**  
Using a torque wrench, apply the specified installation torque to the anchor.

Determine if two M16 diameter SZ-B (Stud) carbon steel High Load anchors with an effective embedment depth  $h_{ef} = 3.94$  inches installed 13 inches from center to center and 5 inches from the edge of a 9 inch deep slab is adequate for a service tension load of 4,000 lb. (live load) and a reversible service shear load of 2,000 lb. (live load). The anchor group will be in the tension zone, away from other anchors in  $f_c = 3,000$  psi normal-weight concrete.

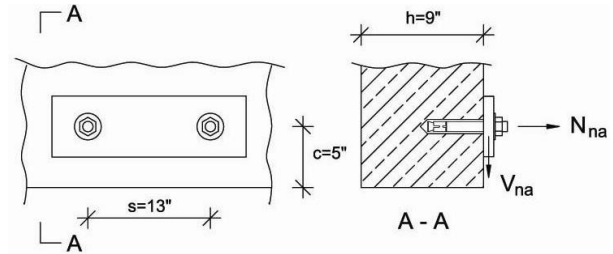

	ACI 318-11 (ACI 318-14) Code Ref.	Report Ref.
<b>1. <u>Verify minimum Member Thickness, Spacing and Edge Distance:</u></b>		
$h = 9 \text{ in.} \geq h_{min} = 7.9 \text{ in.}$ o.k.		Table 1A
$s = 13 \text{ in.} \geq s_{min} = 12.6 \text{ in.}$ o.k.		Table 1A
$c_{a, min} = 5 \text{ in.} \geq c_{min} = 4.7 \text{ in.}$ o.k.		Table 1A
<b>2. <u>Determine the Factored Tension and Shear Design Loads:</u></b> 9.2.1 (5.3.1)		
$N_{ua} = 1.6 L = 1.6 \times 4,000 = 6,400 \text{ lb.}$		
$V_{ua} = 1.6 L = 1.6 \times 2,000 = 3,200 \text{ lb.}$		
<b>3. <u>Steel Capacity under Tension Loading:</u></b> D.5.1 (17.4.1)		
$N_{sa} = 28,171$		Table 2A
$\phi = 0.65$		Table 2A
$n = 2$ (double anchor group)		
Calculating for $\phi N_{sa}$ :		
<b><math>\phi N_{sa} = 0.65 \times 2 \times 28,171 = 36,622 \text{ lb.}</math></b>		
<b>4. <u>Concrete Breakout Capacity under Tension Loading</u></b> D.5.2 (17.4.2)		
$N_{cbg} = \frac{A_{Nc}}{A_{Nco}} \Psi_{ec,N} \Psi_{ed,N} \Psi_{c,N} \Psi_{cp,N} N_b$	Eq.(D-4) (Eq. 17.4.2.1b)	

	ACI 318-11 (ACI 318-14) Code Ref.	Report Ref.
where:		
$N_b = k_c \lambda \sqrt{f_c} h_{ef}^{1.5}$	Eq.(D-6) (Eq. 7.4.2.2a)	
with $k_c = k_{cr} = 21$		Table 2A
$\lambda = 1.0$ for normal-weight concrete		
$\Psi_{ec,N} = 1.0$ since eccentricity $e'_{N} = 0$	Eq.(D-8) (Eq. 17.4.2.4)	
$\Psi_{ed,N} = 0.7 + 0.3 \frac{c_{a,min}}{1.5h_{ef}}$ when $c_{a,min} \leq 1.5h_{ef}$	Eq.(D-10) (Eq. 17.4.2.5b)	
by observation $c_{a,min} = 3 < 1.5h_{ef} = 5.91 \text{ in.}$		
$\Psi_{ed,N} = 0.7 + 0.3 \frac{(5)}{1.5(3.94)} = 0.95$		
$\Psi_{c,N} = 1.0$ assuming cracking at service loads ( $f_t > f_r$ )	D.5.2.6 (17.4.2.6)	
$\Psi_{cp,N} = 1.0$ designed for cracked concrete	D.5.2.7 (17.4.2.7)	
calculating for $\frac{A_{Nc}}{A_{Nco}}$		
$A_{Nco} = 9h_{ef}^2 = 9(3.94)^2 = 139.71 \text{ in.}^2$	Eq. (D-5) (Eq. 17.4.2.1c)	
$A_{Nc} = (c_{a1} + 1.5 h_{ef}) (2 \times 1.5 h_{ef} + s_1)$		
$= (5 + 1.5 \times 3.94) (2 \times 1.5 \times 3.94 + 13)$	Fig. RD.5.2.1 b (Fig. R17.4.2.1b)	
$= 270.8 \text{ in.}^2$		
$\frac{A_{Nc}}{A_{Nco}} = \frac{270.8 \text{ in.}^2}{139.71 \text{ in.}^2} = 1.94$		

**FIGURE 3—SZ EXAMPLE CALCULATION**

	ACI 318-11 (ACI 318-14) Code Ref.	Report Ref.		ACI 318-11 (ACI 318-14) Code Ref.	Report Ref.
Calculating for $N_b$ and $N_{cbg}$ :					
$N_b = 21 \times 1.0 \times \sqrt{3,000} \times (3.94)^{1.5}$ $= 8,995 \text{ lb.}$			$\frac{A_{vc}}{A_{vc0}} = \frac{210}{112.5} = 1.87$	D.6.2.1 (17.5.2.1)	
$N_{cbg} = 1.94 \times 1.0 \times 0.95 \times 1.0 \times 1.0 \times 8,995$ $= 16,579 \text{ lb.}$			calculating for $V_b$ and $\phi V_{cbg}$		
$\phi = 0.65$ for Condition B			$d_a = 0.93 \text{ in.}$		Table 3A
(no supplementary reinforcement provided)		Table 2A	$l_e = 2x d_a = 1.86 \text{ in.}$	D.6.2.2 (17.5.2.2)	
<b><math>\phi N_{cb} = 0.65 \times 16,579 = 10,776 \text{ lb.}</math></b>			$c_{a1} = 5 \text{ in.}$		
5. <u>Pullout Capacity</u>	D.5.3 (17.4.3)		$\phi = 0.70$ for Condition B		Table 3A
not decisive		Table 2A	(no supplementary reinforcement provided)		
6. <u>Check all Failure Modes under Tension Loading:</u>	D.4.1.1 (17.3.1.1)		$V_b = 7 \times \left(\frac{1.86}{0.93}\right)^{0.2} \times \sqrt{0.93} \times 1.0 \times \sqrt{3,000} \times (5)^{1.5} = 4,749 \text{ lb.}$		
Summary:			<b><math>\phi V_{cbg} = 0.70 \times 1.87 \times 1.0 \times 1.0 \times 4,749</math></b> <b><math>= 6,216 \text{ lb}</math></b>		
Steel Capacity = 36,622 lb			9. <u>Concrete Pryout Strength:</u>	D.6.3 (17.5.3)	
Concrete Breakout Capacity = 10,776 lb. ← <b>Controls</b>			$V_{cpg} = k_{cp} N_{cbg}$	Eq. (D-40) (Eq. 17.5.3.1a)	
Pullout Capacity = not decisive			Where:		
<b><math>\phi N_n = 10,776 \text{ lb. as Concrete Breakout Capacity controls}</math></b> <b><math>&gt; N_{ua} = 6,400 \text{ lb. - OK}</math></b>			$k_{cp} = 2.0$ for $h_{ef} \geq 2.5$		
7. <u>Steel Capacity under Shear Loading:</u>	D.6.1 (17.5.1)		$V_{cpg} = 2.0 \times 16,579 = 33,158 \text{ lb.}$ $\phi V_{cpg} = 0.70 \times 33,158 = 23,211 \text{ lb.}$		
Calculating for $\phi V_{sa}$ :			10. <u>Check all Failure Modes under Shear Loading:</u>		
$V_{sa} = 2 \times 19,100 = 38,200 \text{ lb.}$		Table 3A		D.4.1.1 (17.3.1.1)	
$\phi = 0.65$		Table 3A	Summary:		
$\phi V_{sa} = 0.65 \times 38,200 = 24,830 \text{ lb.}$			Steel Capacity = 24,870 lb.		
8. <u>Concrete Breakout Capacity under Shear Loading:</u>	D.6.2 (17.5.2)		Concrete Breakout Capacity = 6,216 lb. ← <b>Controls</b>		
$V_{cbg} = \frac{A_{vc}}{A_{vc0}} \Psi_{ec,V} \Psi_{ed,V} \Psi_{c,V} V_b$			Pryout Capacity = 23,211 lb.		
		Eq. (D-31) (Eq.17.5.2.1b)	<b><math>\phi V_n = 6,216 \text{ lb. as Concrete Breakout Capacity controls}</math></b> <b><math>&gt; V_{ua} = 3,000 \text{ lb. - OK}</math></b>		
where:			11. <u>Check Interaction of Tension and Shear Forces</u>	D.7 (17.6)	
$V_b = 7 \left(\frac{l_e}{d_a}\right)^{0.2} \sqrt{d_a} \lambda_a \sqrt{f'_c} C_{a1}^{1.5}$		Eq. (D-33) (Eq.17.5.2.2a)	If $0.2 \phi V_n \geq V_{ua}$ then the full tension design strength is permitted. D.7.1 (17.6.1)		
$\Psi_{ec,V} = 1.0$ since eccentricity $e'_v = 0$		Eq. (D-36) (Eq.17.5.2.5)	By observation, this is not the case.		
$\Psi_{ed,V} = 1.0$ since $c_{a2} > 1.5c_{a1}$		Eq. (D-37) (Eq.17.5.2.6a)	If $0.2 \phi N_n \geq N_{ua}$ then the full shear design strength is permitted. D.7.2 (17.6.2)		
$\Psi_{c,V} = 1.0$ assuming cracking at service loads ( $f_t > f_r$ )		D.6.2.7 (17.5.2.7)	By observation, this is not the case.		
calculating for $\frac{A_{vc}}{A_{vc0}}$			Therefore		
$h = 9 > 1.5 c_{a1} = 1.5 \times 5 = 7.5 \text{ in.}$			$\frac{N_{ua}}{\phi N_n} + \frac{V_{ua}}{\phi V_n} \leq 1.2$		
$A_{vc} = (2(1.5c_{a1}) + s_1) 1.5c_{a1}$ $= (2 \times 1.5 \times 5 + 13) \times 1.5 \times 5$ $= 210 \text{ in.}^2$		Fig. RD.6.2.1 b (Fig. R17.5.2.1.b)	$\frac{6,400}{10,776} + \frac{3,200}{6,216} = 0.59 + 0.51 = 1.10 \leq 1.2 \text{ - OK}$		
$A_{vc0} = 4.5 (c_{a1})^2 = 4.5 \times 5^2 = 112.5 \text{ in.}^2$		Eq. (D-32) (Eq. 17.5.2.1c)	12. <u>Summary</u>		
			<b>Two M16 diameter SZ High Load anchors at 3.94 in. effective embedment depth are adequate to resist the applied service tension and shear loads of 4,000 lb. and 2,000 lb., respectively.</b>		

FIGURE 3—SZ EXAMPLE CALCULATION (Continued)

**DIVISION: 03 00 00—CONCRETE**

Section: 03 16 00—Concrete Anchors

**DIVISION: 05 00 00—METALS**

Section: 05 05 19—Post-installed Concrete Anchors

**REPORT HOLDER:**

MKT METALL-KUNSTSTOFF-TECHNIK GmbH &amp; Co. KG

**EVALUATION SUBJECT:**

MKT SZ CARBON STEEL AND SZ A4 STAINLESS STEEL, HIGH LOAD ANCHORS FOR CRACKED AND UNCRACKED CONCRETE

**1.0 REPORT PURPOSE AND SCOPE****Purpose:**

The purpose of this evaluation report supplement is to indicate that the MKT SZ High Load Anchors, described in ICC-ES evaluation report ESR-3173, have also been evaluated for compliance with the codes noted below.

**Applicable code edition:**

- 2019 *California Building Code (CBC)*

For evaluation of applicable chapters adopted by the California Office of Statewide Health Planning and Development (OSHPD) aka: California Department of Health Care Access and Information (HCAI) and Division of State Architect (DSA), see Sections 2.1.1 and 2.1.2 below.

- 2019 *California Residential Code (CRC)*

**2.0 CONCLUSIONS****2.1 CBC:**

The MKT SZ High Load Anchors, described in Sections 2.0 through 7.0 of the evaluation report ESR-3173, comply with CBC Chapter 19, provided the design and installation are in accordance with the 2018 *International Building Code*® (IBC) provisions noted in the evaluation report and the additional requirements of CBC Chapters 16 and 17.

**2.1.1 OSHPD:** The applicable OSHPD Sections of the CBC are beyond the scope of this supplement.

**2.1.2 DSA:** The applicable DSA Sections of the CBC are beyond the scope of this supplement.

**2.2 CRC:**

The MKT SZ High Load Anchors, described in Sections 2.0 through 7.0 of the evaluation report ESR-3173, comply with CRC Section R301.1.3, provided the design and installation are in accordance with the *International Building Code*® (IBC) provisions noted in the evaluation report and the additional requirements of CBC Chapters 16 and 17.

This supplement expires concurrently with the evaluation report, reissued December 2020 and revised June 2022.